

ELECE



ESPECIFICACIONES TÉCNICAS

POTENCIA MÁX. (KVA)	9,5
TENSIÓN (V)	220
SALIDA (12V)	No
FRECUENCIA (Hz)	50
FACTOR DE POTENCIA	1
TIPO DE ARRANQUE	Eléctrico
MOTOR DIESEL	KM2V80
POTENCIA	20
CILINDROS	2
CILINDRADA (cc)	794
CAPACIDAD ACEITE (Lts)	2,27
CAPACIDAD TANQUE (Lts)	26
CONSUMO (Lts/h)	3,7
AUTONOMÍA (Hs)	7
NIVEL SONORO (dB a 7 mt)	85
DIMENSIONES(L*A*H mm)	1030*600*790
PESO (Kg)	235
BATERÍA	Si

MODELO

KDE12EAF

MARCA

KIPOR

TIPO DE ALIMENTACIÓN

DIESEL



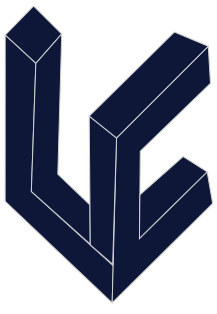

ELECE

DIESEL

KIPOR®

GRUPO ELECTRÓGENO | 9.5 KVA

CARACTERÍSTICAS PRINCIPALES



Lógica digital



Salida de escape



Medidor y tanque de combustible



Bornera de conexión

DIMENSIONES Y PESO

PESO 235kg

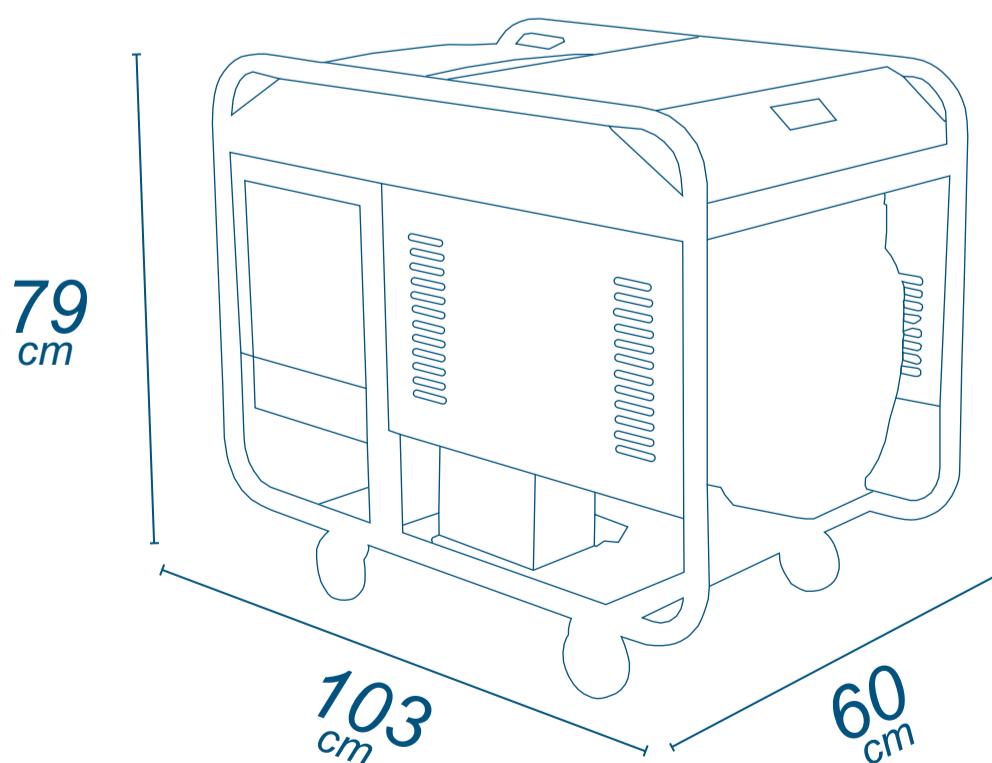

OPCIONALES

TABLERO AUTOMÁTICO

